



Owner's Manual

NMV / NMR Inbuilt Appliances



TESTED IN ACCORDANCE WITH AS/NZS 4013:2014 and AS/NZS 2918.

Please read this manual thoroughly before installing and starting your free-standing appliance.

Keep these instructions for future reference

V12072018



Index

1. Introduction	03
2. Appliance Layout	05
3. Technical Specifications	06
4. Installation Instructions	09
Chimney build out Version	10
Cabinetry / Full Wall Build Install / Zero Clearance	15
Ducting	20
Flue Outlet	23
5. Fan	26
6. Instructions for use	28
7. Cleaning and Maintenance	30
8. Troubleshooting	32
9. Warranty	33

CE Marking label with serial number

1. Introduction

Congratulations on your purchase of your new ADF woodfire appliance!

Years of extensive research and dedication to innovation and quality, since 1976, has resulted in these beautifully designed European appliances, constructed to strict Portuguese and European legislation, and tested and Certified to the Australian Emissions, Efficiency and Safety standard requirements guaranteeing excellent performance.

Please read this manual fully to ensure safe and efficient use of your heater and to comply with the warranty guidelines.

Solid Fuel – Ecological Energy

Through photosynthesis, plants capture energy from the sun and transform it into chemical energy. The trapped energy, eg in the form of wood, pellets, coal are called biomass fuels and can be converted into various forms: electricity, fuel or heat. Biomass burning causes the release of carbon dioxide into the atmosphere, but since this compound had previously been absorbed by the plants that originated the fuel, the CO₂ emissions balance is zero, not contributing to the greenhouse effect on the planet. Firewood is the most environmentally friendly way of producing heat in your home, as it is a fully renewable resource. The amount of CO₂ that is released during the combustion of firewood is not higher than the amount that would be released from its natural decomposition. Wood ash is a mineral fertilizer easily absorbed by the environment in a totally ecological way.

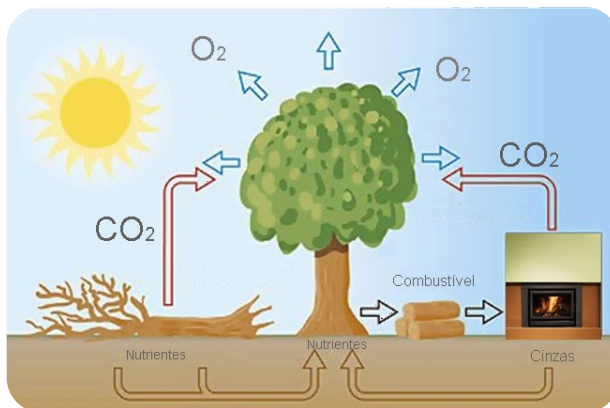

Firewood – Use

Choosing your wood

All wood types have a different calorific value. You should choose only well-seasoned hard woods. Do not use logs that are too large. Split round logs so they cannot roll and cause a hazard.

Drying your wood

Whichever firewood is chosen, it must be very dry and seasoned. Unseasoned or green firewood does not heat as much, because a large part of the energy is consumed in the evaporation of the water and creosote contained in the wood, which is highly corrosive and will damage the appliance and consequently it could void your Warranty. In addition, moist firewood produces a large amount of smoke and little flame, which will foul the appliance, the glass and the chimney. When raining the stored wood should be covered and well ventilated. Generally, green wood should be left to “season” for two years.

Wood to Avoid

Softwoods and low-density wood: This kind of firewood release a lot of heat but burn too quickly and projects embers and resin that foul the chimney and the interior of your woodstove. These should be used as Kindling only, for starting your fire.

Do not use:

Wood with varnish, exotic wood, treated/painted timber, agglomerates that can produce toxic fumes which will damage the appliance. Do not use drift wood or coastal wood with high salt content, it will quickly damage the heater.

All ADF appliances are designed to burn firewood and firewood only, with less than 20% moisture content. The use of unseasoned firewood or firewood with moisture or other types of fuel not recommended will void the warranty. See below, the drier the wood the better heat you get out of it.

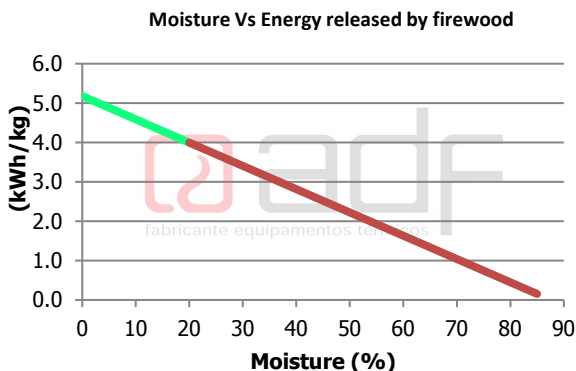

2-Appliance Layout



Pos.	Designation
1	Door lever, Tool supplied for Door and Air Control
2	Combustion Air control (Use tool): Open (+) slide to the right Close (-) slide to the left
3	Vermiculite brick lining
4	Primary convection outlet
5	Secondary convection outlet (hot air distribution for ducting) Inbuilt only
6	Smoke Outlet – Flue collar 200mm (8” Crimped)
7	Convection inlet

Important:

- Please read this manual thoroughly before installing and starting your free-standing appliance.
- Installation must be carried out by a licenced and certified installer.
- Keep these instructions for future reference

3- Technical Specification

Specifications	Unit	820	1000
TESTED IN ACCORDANCE WITH AS/NZS 4012:2014 & AS/NZS 4013:2014			
Burning Harwood			
Maximum Average Heat Output	kW	9.7	12.5
Overall Average Efficiency	%	63	64
Particulate Emission Factor	g/kg	0.8	1.2
Maximum firewood load	kg	9.7	13.7
Minimum clearance distances from combustibile materials	mm	See page 10/15.	See Page 10/15.
Flue Diameter	mm	200	200
Recommended Fuel	Burn only Harwood Moisture ≤ 20%		
Electrical Specification	W	36	
	V	220-240	
	Hz	50/60	
Fan Settings	Thermostat Low, Manual High.		

Model	Width	Depth	Height	Weight
Dimensions (mm)				
ADF820NM-RS Freestanding with Bench	832	445	860	198
ADF820NM-RS Freestanding with Bench and Fan	832	445	860	200
ADF820NMV-B Freestanding with Fan	832	450	565	160
ADF1000NMV-B Freestanding	1012	450	465	172
ADF1000NMV-B Freestanding with Fan	1012	450	565	174
ADF1000NMV-P Pedestal Freestanding	1012	450	865	206

 **WARNINGS:**

A wood burning heater is, by its nature, an appliance that operates at high temperatures, so it is necessary to take into account potential risk factors that should be avoided at all costs. Children must be kept away from any combustion appliance and supervised in the room at all times.

Installation must be carried out by a licenced and certified installer.

The installation must meet the requirements of the manufacturers instructions, AS2918 and the Building Code of Australia.

The appliance must be installed in such a way as to allow easy maintenance. Incorrect installation may cause serious damage to the equipment and the safety of people and property.

Before installing your appliance, please ensure the following:

- The appliance must be installed on a heat resistant surface to 600°C.
- The floor must be structurally sound, to support the installation weight.
- Replacement outside air must be supplied to the room with the heater, a minimum equivalent to half the cross-sectional area of the flue, ie 160cm² free air.
- Your appliance must be non-permanently installed and easily accessible to ensure general maintenance (chimney and equipment).
- The appliance must not be cemented in its enclosure under any circumstances. 3 – 5mm clearance is required between the heater outer skin and construction materials, to allow for metal expansion.

Keep these instructions for future reference

 **WARNINGS:**

- REFER TO COMPLIANCE LABEL – DISREGARD ANY CONTRADICTIONARY FUEL TYPE INFORMATION IN INSTRUCTION MANUAL
- **WARNING: THE APPLIANCE & FLUE SYSTEM SHALL BE INSTALLED IN ACCORDANCE WITH AS/NZS 2918:2001 AND THE APPROPRIATE REQUIREMENTS OF THE RELEVANT BUILDING CODE OR CODES.**
- **WARNING: APPLIANCES INSTALLED IN ACCORDANCE WITH THIS STANDARD SHALL COMPLY WITH THE REQUIREMENTS OF AS/NZS 4013:2014 WHERE REQUIRED BY THE REGULATORY AUTHORITY, I.E. THE APPLIANCE SHALL BE IDENTIFIABLE BY A COMPLIANCE PLATE WITH THE MARKING “TESTED TO AS/NZS 4013:2014”.**
- **ANY MODIFICATION OF THE APPLIANCE THAT HAS NOT BEEN APPROVED IN WRITING BY THE TESTING AUTHORITY IS CONSIDERED TO BE IN BREACH OF THE APPROVAL GRANTED FOR COMPLIANCE WITH AS/NZS 4013:2014.**



WARNINGS:

- CAUTION: MIXING OF APPLIANCE OR FLUE SYSTEM COMPONENTS FROM DIFFERENT SOURCES OR MODIFYING THE DIMENSIONAL SPECIFICATION OF COMPONENTS MAY RESULT IN HAZARDOUS CONDITIONS. WHERE SUCH ACTION IS CONSIDERED, THE MANUFACTURER SHOULD BE CONSULTED IN THE FIRST INSTANCE.
- CAUTION: CRACKED AND BROKEN COMPONENTS, e.g. GLASS PANELS OR CERAMIC TILES, MAY RENDER THE INSTALLATION UNSAFE.
- **WARNING: ANY MODIFICATION OF THE APPLIANCE THAT HAS NOT BEEN APPROVED IN WRITING BY THE TESTING AUTHORITY IS CONSIDERED AS BREACHING AS/NZS 4013.**
- **WARNING: DO NOT USE FLAMMABLE LIQUIDS OR AEROSOLS TO START OR REKINDLE THE FIRE.**
- **WARNING: DO NOT USE FLAMMABLE LIQUIDS OR AEROSOLS IN THE VICINITY OF THIS APPLIANCE WHEN IT IS OPERATING.**
- **WARNING: DO NOT STORE FUEL WITHIN THE HEATER INSTALLATION CLEARANCES.**
- **WARNING: WHEN OPERATING THIS APPLIANCE AS AN OPEN FIRE USE A FIRE SCREEN.**
- **WARNING: OPEN AIR CONTROL (AND DAMPER WHEN FITTED) BEFORE OPENING FIRING DOOR.**
- CAUTION: THIS APPLIANCE SHOULD NOT BE OPERATED WITH A CRACKED GLASS.
- THIS APPLIANCE SHOULD BE MAINTAINED AND OPERATED AT ALL TIMES IN ACCORDANCE WITH THESE INSTRUCTIONS.
- THE USE OF SOME TYPES OF PRESERVATIVE-TREATED WOOD AS A FUEL CAN BE HAZARDOUS.
- THE APPLIANCE OR FLUE SYSTEM SHOULD NOT BE MODIFIED IN ANY WAY WITHOUT THE WRITTEN APPROVAL OF THE MANUFACTURER.
- BURN ONLY HARDWOOD
- Prior to installation check with your state and local authorities regarding any specific regulations that may apply.

All local regulations, including those referring to national standards, must be observed when installing the appliance.



4-Installation Instructions

The floor must be structurally sound.

The Hearth must have a heat resistant surface to 600°C, with an insulating thickness of non-combustible material equivalent to 24mm of cement sheet with thermal conductivity of 0.1m².K/W per 9mm. eg 24mm Bellis Board or equivalent.

Dimensions required in front of the heater are shown in the Elevation drawings below. The hearth must be included beneath the heater (eg 40mm Skamotec).



Heater with Fan option.

If the heater is supplied with legs to protect the Fan during transit; lay the heater on its back, to remove the legs. The heater can then be carefully put into position. The Heater will need to be inserted into the chimney build out before the construction is completed.

The Installations can be included into a Masonry installation, built as a default non-combustible chimney opening meeting the requirements for the National Construction Code or the Building Code of Australia.

The tested installation is built into Skamotec 225. This can be done in 2 ways:

1. Chimney Build Out version (no combustibles within 50mm of each side wall, or
2. Cabinetry version; if Combustible materials will be built alongside the installation. This version includes as extra side cavity with 50mm clearance each side. See below.

Note:

An Optional Kit form is available for the Chimney Build Out version.

1. Chimney Build Out Install:

The build out is constructed with Skamotec 225 40mm sheets to Skamotec specifications, the Installation and Clearance specifications are included in the Elevation drawings shown below:

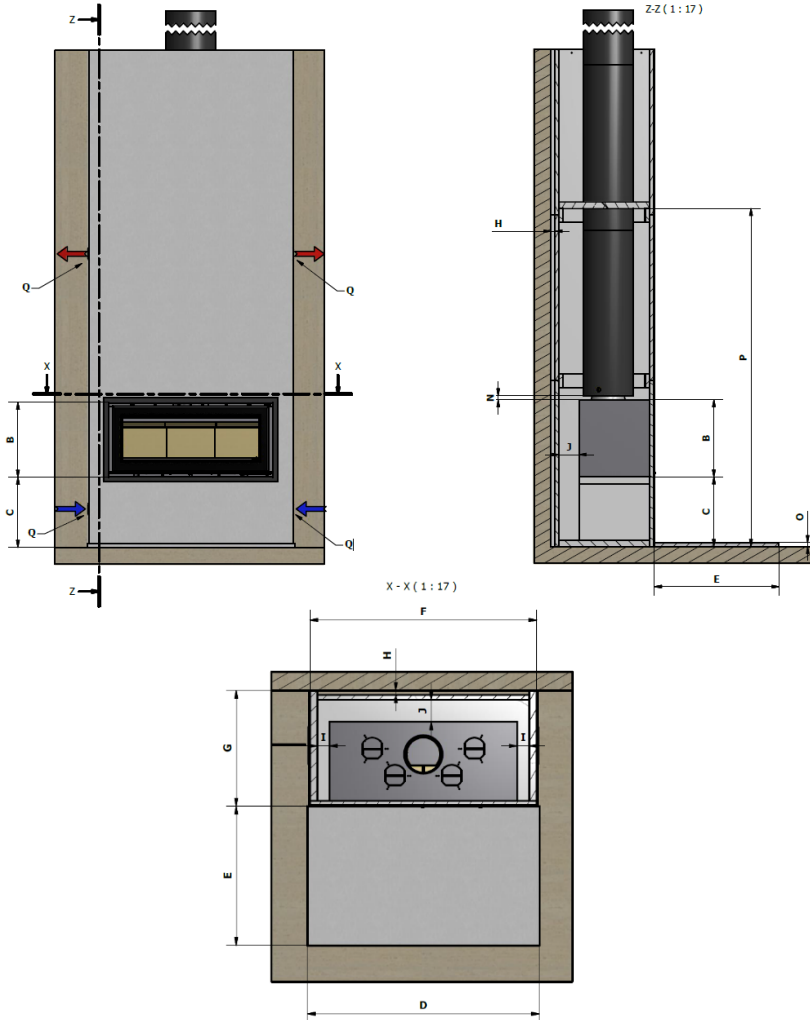

Installation and Clearance Specifications

-	A	B	C	D	E	F	G	H	I	J	L*	N	Y	P	Q*
820 NMV	840	470	420	1070	650	1042	620	≥25	≥65	≥120	2 (≥60x400)	25	18	≥1800	4 (≥60x200)
1000 NMV	1020	470	250	1250	750	1222	620	≥25	≥65	≥120	2 (≥60x400)	25	24	≥1800	4 (≥60x200)

* Note: Vents in position L (Frontal) or Q (Lateral).

The parts list required for the build out is shown

Chimney Built Out Parts List

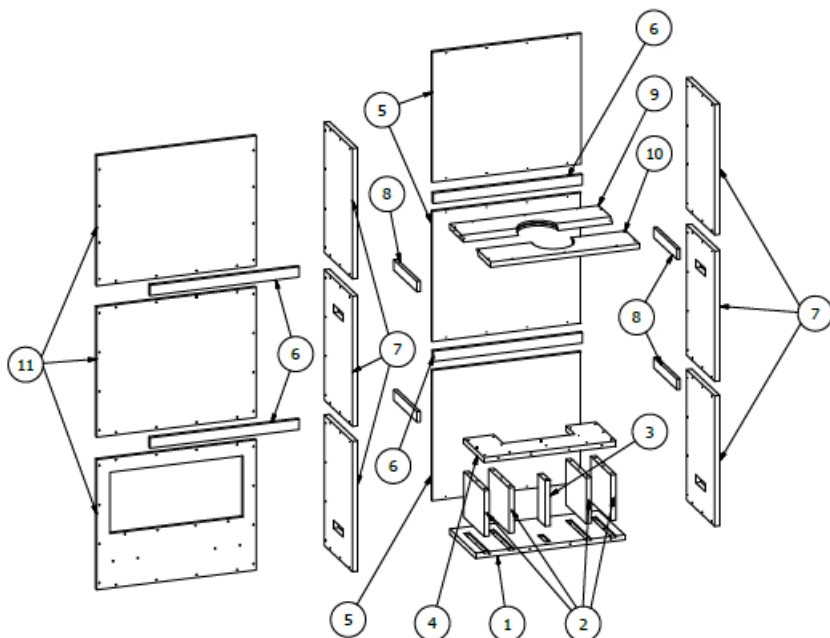

Parts List – Chimney Build out				
Nº	Qty.	Description	RC 820 NMV	RC 1000 NMV
1	1	Skamotec 40mm thick	965 x 545	1145 x 545
2	4	Skamotec 40mm thick	425 x 350	425 x 350
3	1	Skamotec 40mm thick	350 x 155	350 x 155
4	1	Skamotec 40mm thick	835 x 425	1015 x 425
5	3	Skamotec 25mm or 40mm thick	965 x 1000	1145 x 1000
6	4	Skamotec 25mm or 40mm thick	965 x 80	1145 x 80
7	6	Skamotec 40mm thick	1000 x 595	1000 x 595
8	4	Skamotec 25mm or 40mm thick	490 x 80	490 x 80
9	1	Skamotec 40mm thick	965 x 295	1145 x 295
10	1	Skamotec 40mm thick	965 x 290	1145 x 290
11	3	Skamotec 25mm or 40mm thick	1045 x 1000	1225 x 1000

Note: 4 vent at 60 x 200 as shown, or include
In front panel as pes cabinety / wall build ent

The construction of the base includes 5 pillars and a base to support the heater, leaving cut out for the fan to drop into. The bench cut out is 560mm x 230mm from the rear of the base.

The assembly includes a 30mm air gap behind the rear sheet to combustible material. Use Skamotec off cuts to space out from the wall. The side walls continue to the rear wall, enclosing the gap.

The minimum Ventilation area must be included below the base of the heater and below the cap (9 and 10). The ventilation can be included in the front to the dimensions at L or on the sides, shown as Q. The same total vent area is included below the base of the firebox, and at the top below the ceiling cap height of the chimney chase, in either case.

STEP 1.

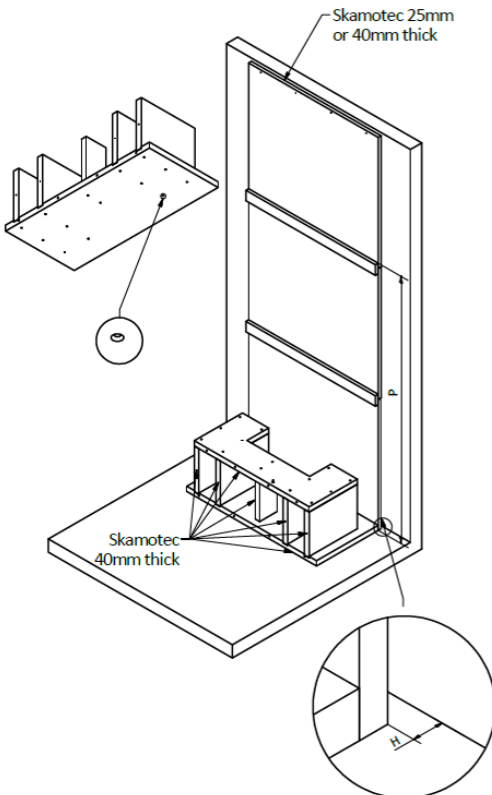

STEP 2.

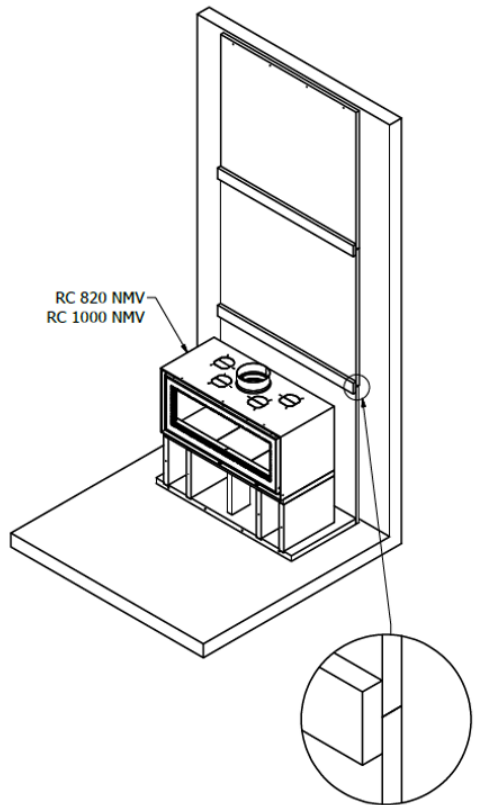

STEP 3.

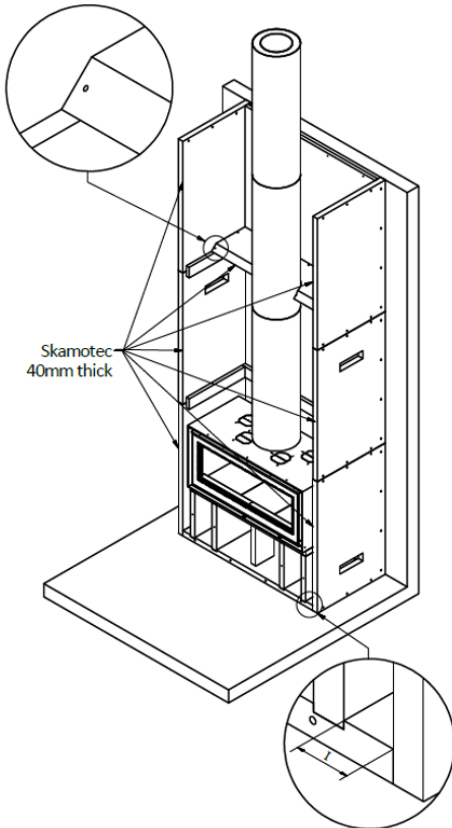

STEP 4.

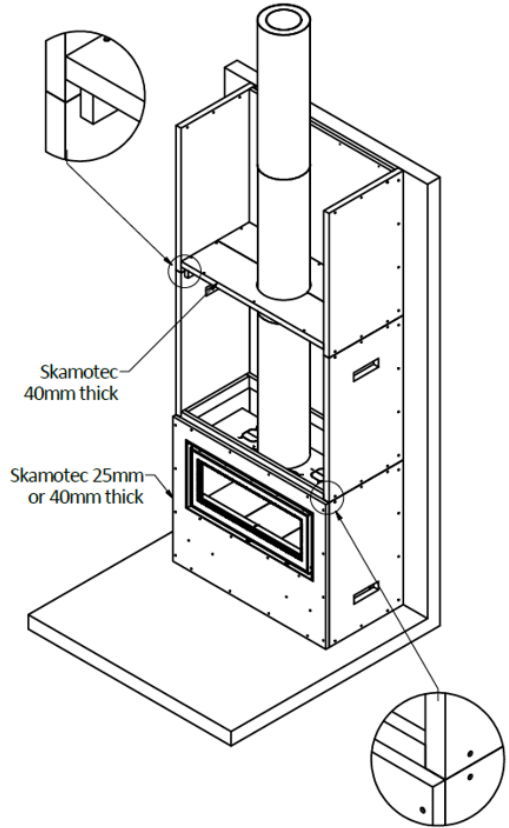

STEP 5.

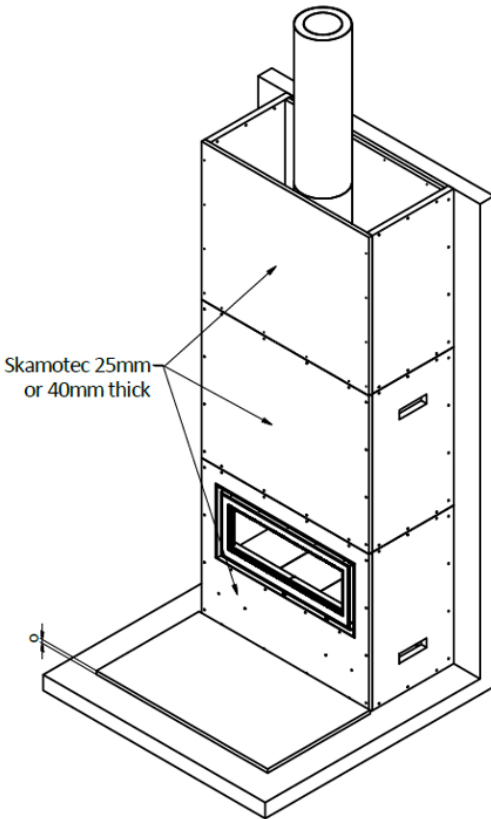

STEP 6.

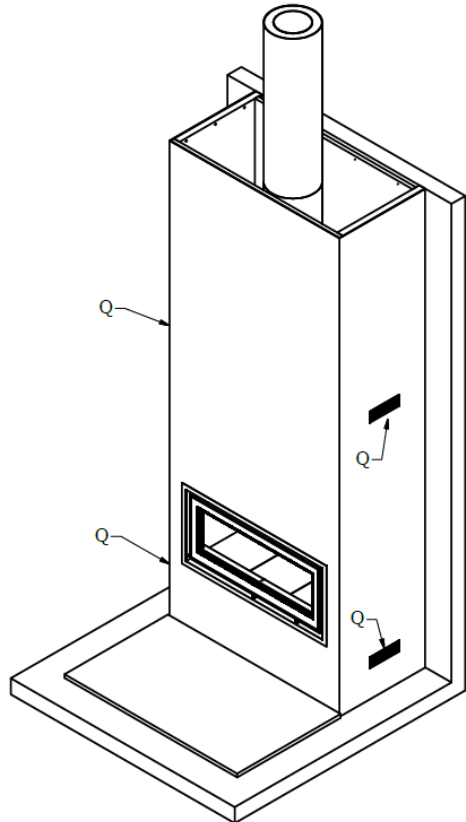

Cabinetry / Full Wall Build Install:

Allows combustible materials to be built up to the side of the enclosure.

The build out is constructed with Skamotec 225 40mm sheets to Skamotec specifications, the Installation and Clearance specifications are included in the Elevation drawings shown below:

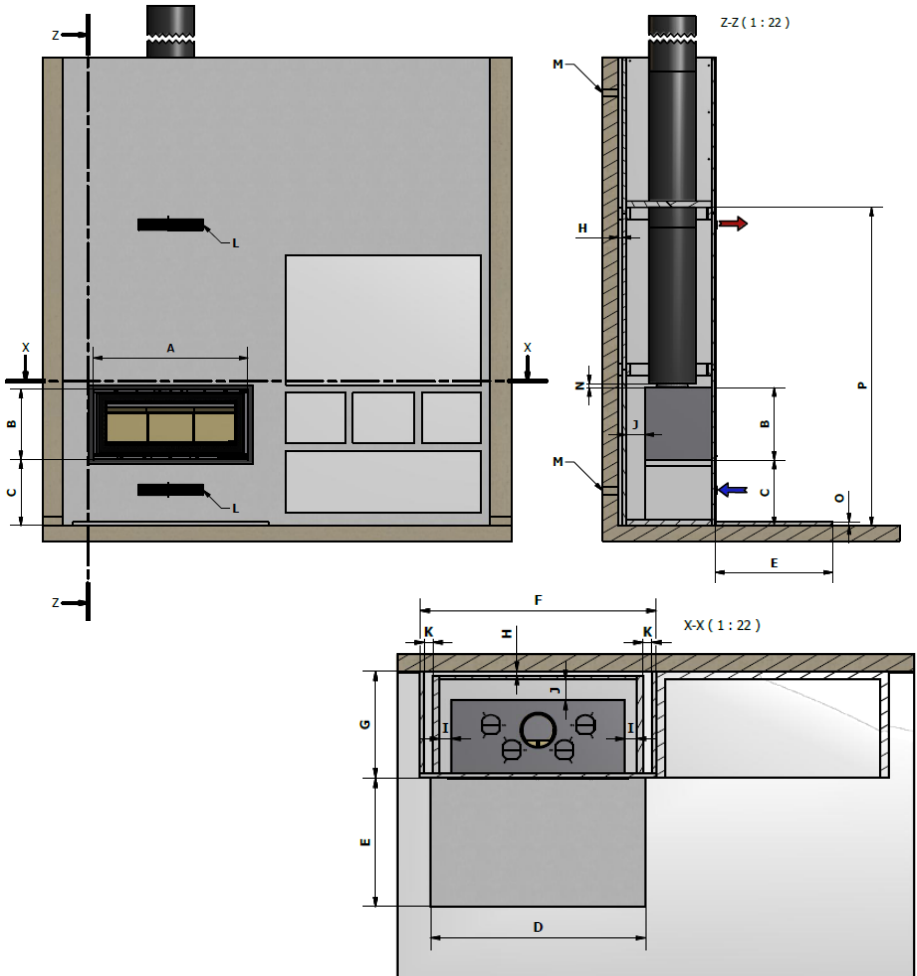

Installation and clearance specifications

-	A	B	C	D	E	F	G	H	I	J	K	L	M	N	O	P
820 NMV	840	470	420	1070	650	1192	620	≥25	≥65	≥120	≥50	2 (≥60x400)	4 (50x50)	25	18	≥1800
1000 NMV	1020	470	250	1250	750	1372	620	≥25	≥65	≥120	≥50	2 (≥60x400)	4 (50x50)	25	24	≥1800

The parts required for the build out is shown below:

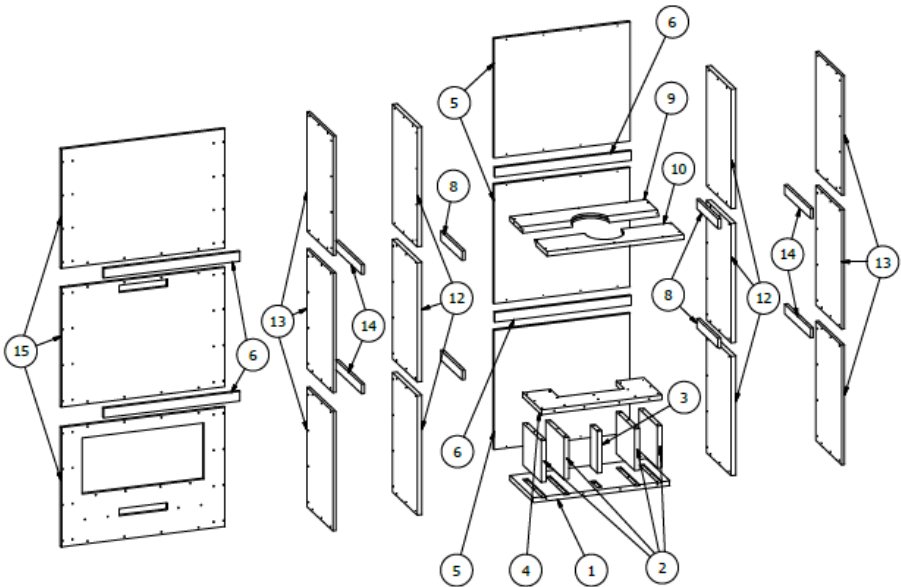

Parts List – Cabinetry full wall Install				
Nº	Qty.	Description	RC 820 NMV	RC 1000 NMV
1	1	Skamotec 40mm thick	965 x 545	1145 x 545
2	4	Skamotec 40mm thick	425 x 350	425 x 350
3	1	Skamotec 40mm thick	350 x 155	350 x 155
4	1	Skamotec 40mm thick	835 x 425	1015 x 425
5	3	Skamotec 25mm or 40mm thick	965 x 1000	1145 x 1000
6	4	Skamotec 25mm or 40mm thick	965 x 80	1145 x 80
8	4	Skamotec 25mm or 40mm thick	490 x 80	490 x 80
9	1	Skamotec 40mm thick	965 x 295	1145 x 295
10	1	Skamotec 40mm thick	965 x 290	1145 x 290
12	6	Skamotec 40mm thick	1000 x 570	1000 x 570
13	6	Skamotec 25mm thick	1000 x 585	1000 x 585
14	6	Skamotec 25mm thick	585 x 80	585 x 80
15	3	Skamotec 25mm or 40mm thick	1195 x 1000	1375 x 1000

The construction of the base includes 5 pillars and a base to support the heater, leaving cut out for the heater fan to drop into. The bench cut out is 560mm x 230mm from the rear of the base.

The assembly includes a 30mm air gap behind the rear sheet to combustible material. Use Skamotec off cuts to space out from the wall.

STEP 1.

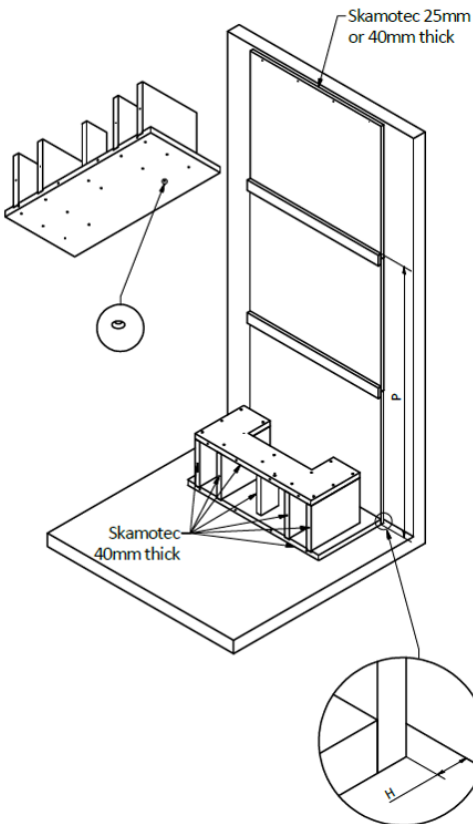

STEP 2

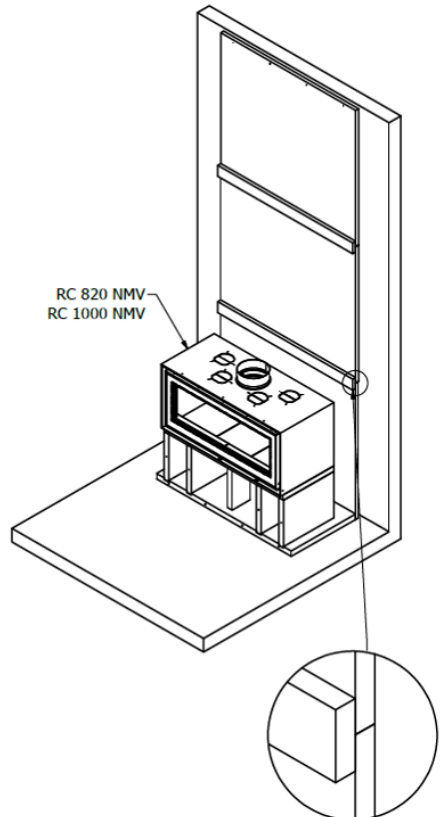

The minimum Ventilation area must be included below the base of the heater and below the cap (9 and 10). The ventilation is shown in the front as the dimensions at L. If an alternative ventilation position is required, ample free air flow must have access to the ventilation from outside the cavity. The total vent area must be included below the base of the firebox, and at the top below the ceiling cap height of the chimney chase.

STEP 3.

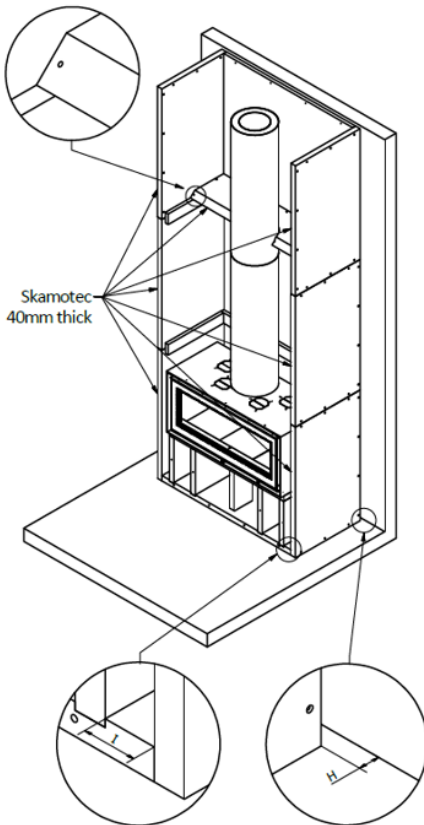

STEP 4.

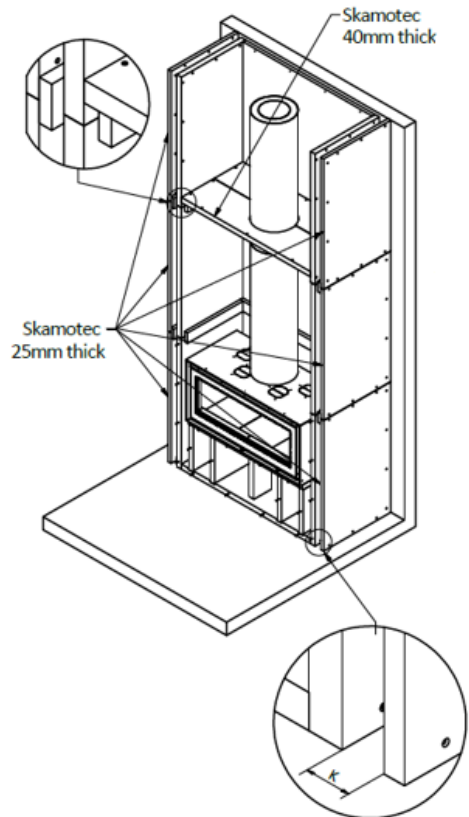

STEP 5.

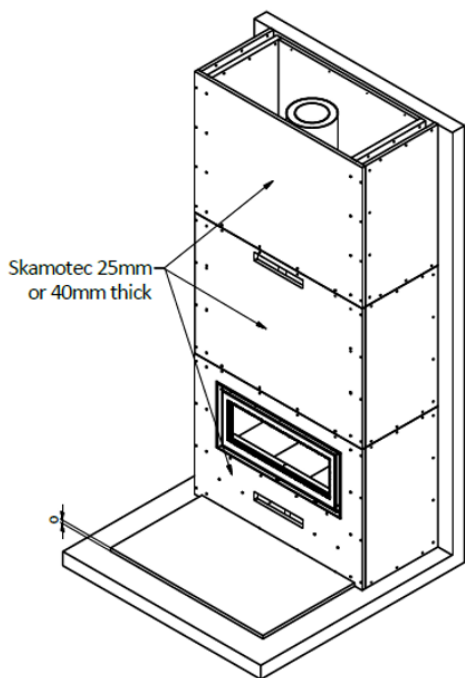

STEP 6.

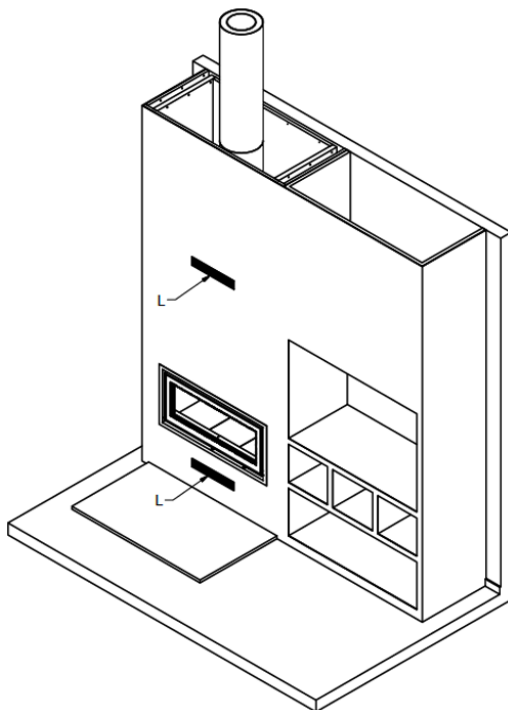

Ducting – Convection Air Transfer Ducting

For the inbuilt models, Ducting can be added to the top of the firebox and transferred to vents either on side of the Chimney breast via natural convection, or via an air transfer kit with fan to other rooms (From other supplier). The blanking plates can be opened as below, to direct the convection heat into the duct, which will also be forced via the heater fan (if fitted).

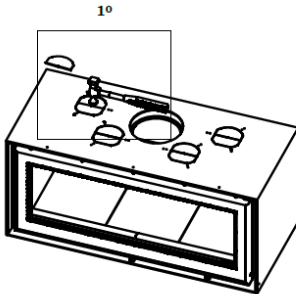

1. To open the blanking plate on top of the heater box, heat the REAR section only of blanking plate, with a hammer to punch out.

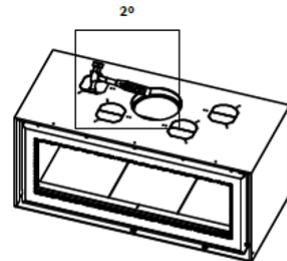
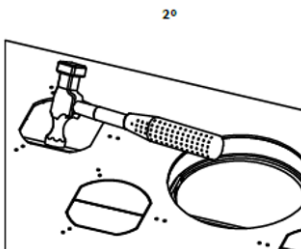
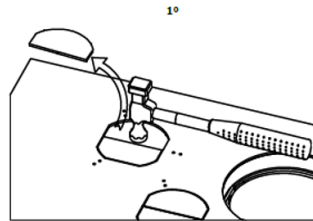

2. Fold the FRONT section of the blanking plate downward. This will force the fan blown air into

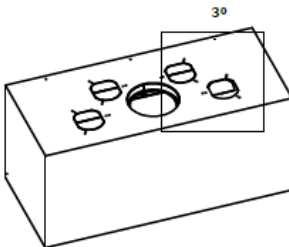

3. Fix the optional Accessory Duct collar with self tapping screws to top of the firebox, covering the opening. Standard 100mm duct will fit to the duct collar, to transfer heat from the Firebox or wall cavity back into the home.

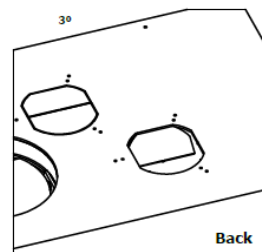

4º

Fit a Ducting collar to the top of the fire box and fit ducting as required (From other supplier).

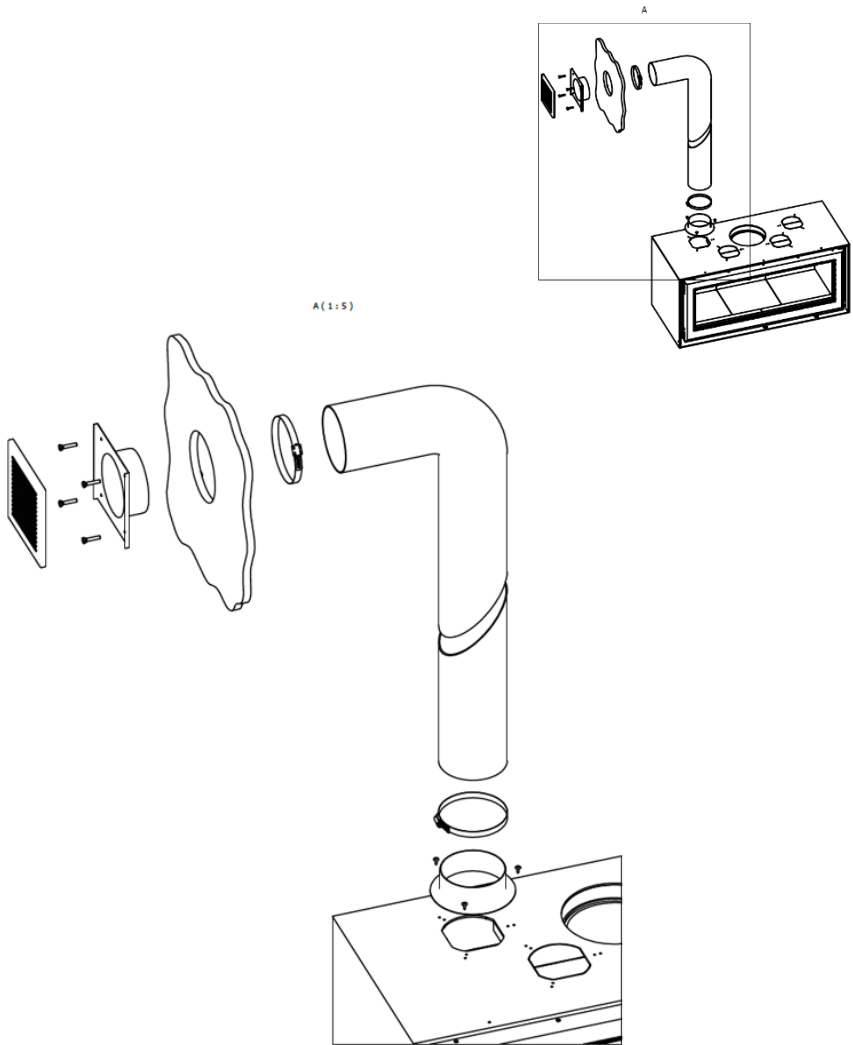

Framing

Beading in metal or plastic cannot be used around the firebox opening due to heat. Metal expansion could crack the Skamotec.

Ensure there is an expansion gap between the heater box and the Skamotec, of 3 or 4mm.

A Frame can be fitted as follows to cover the gap between the heater and the appliance:

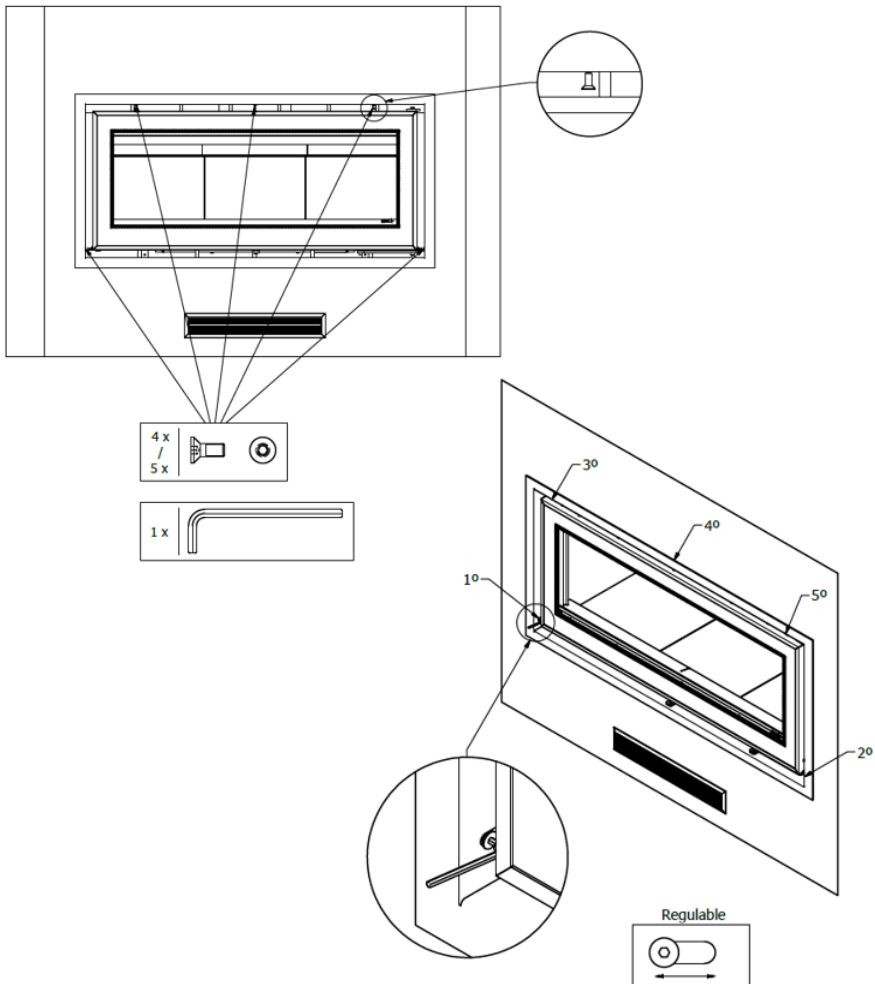

Skamotec 225 can be finished with:

1. EasyMix render (Wet boards thoroughly before applying mix) then painted.
2. Smooth wall plaster (Prime the board first to increase working time, with suitable priming compound, check with your board supplier), then skim coated and painted.
3. Tiling (Prime the board first before tiling adhesive, with suitable priming compound, check with your board supplier).
4. For more information check with your Skamotec supplier or Castworks.

Ensure there is a gap of 5mm between the heater metal and the Skamotec 225, to allow for metal expansion.

Fibreglass mesh tape should be used on all joins. No combustible products should be used in the combustible clearance zone.

Metal or plastic beading can be used on the corners, but no closer than the minimum external sizes shown on page 10.

Flue Installation

Flue type: Triple skin flue, 200mm/250mm/300mm or 8"/10"/12". The Active 200mm flue must be a tight fit into the heater collar. Double casing outer skins 250mm and 300mm begin 25mm above heater to allow air flow into these outer casings. The cavity must be ventilated to allow this air flow.

The heater must have its own dedicated flue. The active flue must be 8" for the entire length of the flue, and always less than 45 degrees from the vertical.

Replacement room air from outside equivalent to 160cm² must be supplied into the room.

Flue Outlet Positions

The Flue terminal must meet the minimum height and external clearances for the flue, according to AS/NZ 2918:2018, see the diagram shown below.

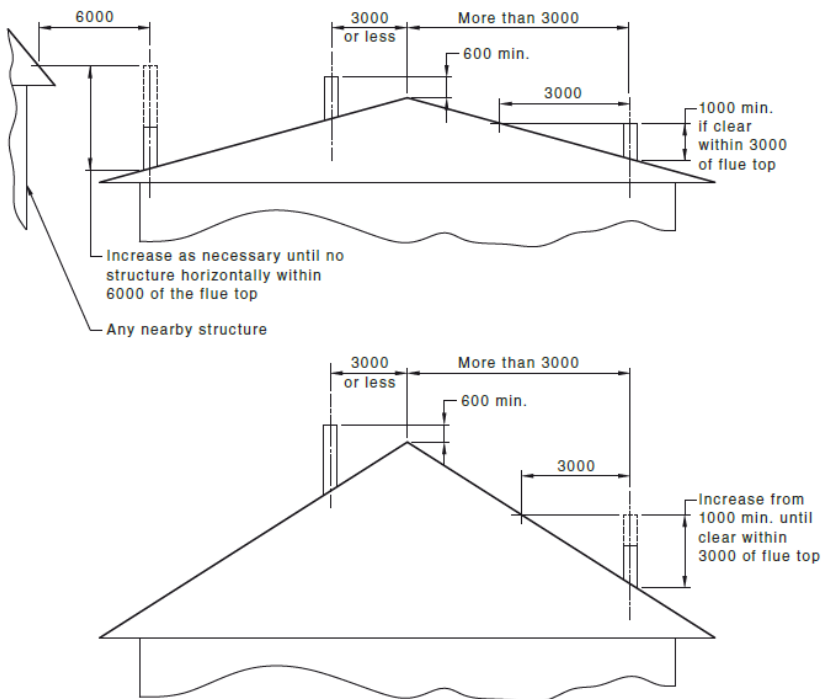

DIMENSIONS IN MILLIMETRES

NOTE: Flue exit MUST be also be as high as any nearby structure within a 6m Radius. (AS 2918:2018)

External Requirements

Refer to AS/NZS 2918:2018

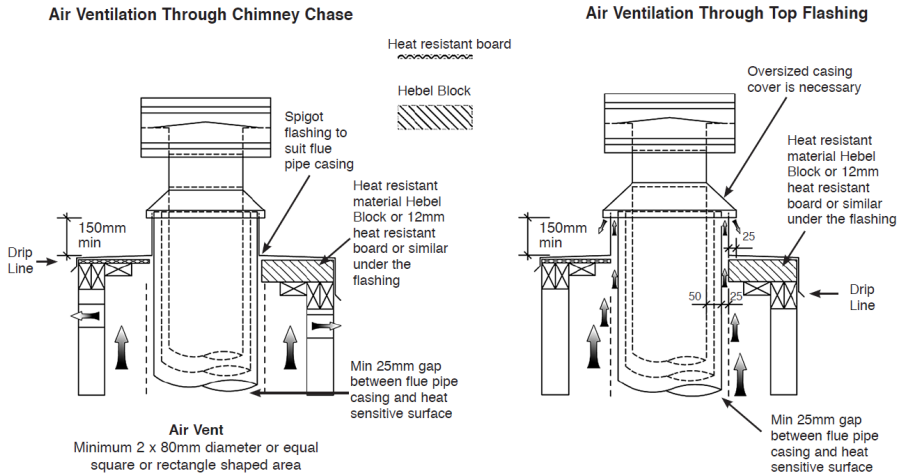

Note: All external air vents & ceiling penetrations must be bird & rodent proofed with permanently fixed screens

5- Fan (for fan models only).

- Must be installed in accordance with AS/NZS 3000.
- Must be installed to the manufacturers specifications.
- Power supply must be installed by a licensed electrician.
- If the power cable is damaged, for any reason, do not use. Have the cord replaced immediately.

The cable for the electrical supply with Plug is 1.5m.

The cable for the control switch is 65cm. It is made with a high temperature rated silicon outer case. If additional cabling is required check with your electrician.

Mount the control switch into wall where required. Do not mount in wall above the heater or within 65mm from each side of the heater.

Electric circuit layout

Fan operation modes:

I- Low speed

Thermostat setting (>50C), (Automatic on/off)

0-OFF

II-Manual setting, High speed

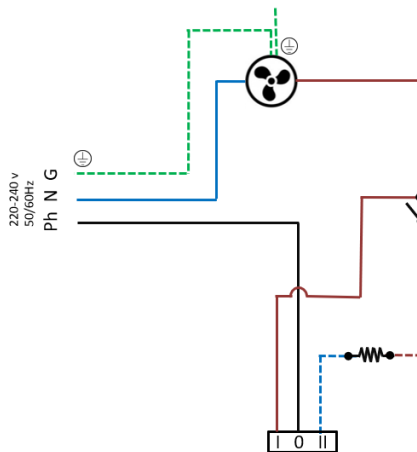









Warnings

Danger of Electrocution: All electrical work must be carried out by a qualified electrician.

Note: All electrical components should be installed in an airy location away from hot parts

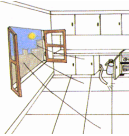
Important Recommendations

	<p>The heater must be installed by a qualified and accredited professional.</p>
	<p>Caution: the outside surfaces of the equipment are hot; wear suitable protective gloves whenever you need to touch hot parts of the appliance and when loading firewood into the heater.</p>
	<p>Do not use the appliance as your incinerator. The combustion of domestic waste can cause the release of toxic fumes and cause early corrosion of the components of your equipment and void your warranty.</p>
	<p>This appliance is not a toy! Keep children away at all times.</p>
	<p>Check that the exhaust system is well dimensioned, ensuring proper drainage and that it complies with the Australian standards in force, so that there is no undue smoke escape into the surrounding space.</p>
	<p>Keep combustible and flammable materials at a safe distance from the appliance (minimum 1.5 meters).</p>
	<p>NEVER use liquid fuel .</p>
	<p>During the first use, curing of the paint occurs – which may give off some odours. Avoid inhalation and keep the area well ventilated. The first 2 firings should be made with a small kindling fires with a minimal amount of wood, in order to favour the dissipate of the metal tension and let the paint cure slowly, so it does not present imperfections later on.</p>
	<p>In case of adverse atmospheric conditions that disturb the drawing of smoke, it is advisable not to use the appliance.</p>

6- Instructions for Use

Combustion Control:

Open (+), slide to the right
Close (-), slide to the left

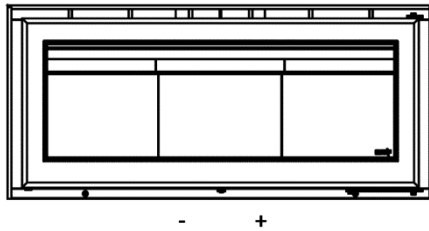

Ignition

1. It is extremely important, when first using or lighting for the first time for the season, to thoroughly examine the chimney and to make sure it is clean and unobstructed. Ensure the Chimney is swept regularly; If necessary contact your local chimney sweep.
2. Do not overload the appliance, the appliance is designed to display a beautiful flame pattern.
3. Completely open the combustion air control, pushing it to the right. On the base of the fire use a small amount of easily flammable material such as crunched up paper, firelighters, pine cones. Then lay fine kindling around and on this base in such a way that they are interlocking and self-supported, thus allowing air to flow around them and without the pile collapsing and suffocating.
4. Once the kindling is well alight, add some small split logs to the kindling stack, resting against each other or the back wall so the kindling doesn't collapse. Use about 1kg of split dry small logs of dry wood.
5. Keep the door slightly open, allowing the amount of air needed for a quick and efficient ignition, keeping the combustion air control fully open. Never leave the fire unattended whilst the door is left ajar.
6. After 5 minutes close the door and reduce the combustion air control to reduce the combustion air intake
7. There should be a good amount of coals

After Firing

1. Slowly open the door, spread the embers evenly across the furnace base.
2. Place the wood logs (approximately 1 - 2kg each) horizontally left to right, keeping the log away from the door glass. Do not overload the appliance – check your model in the specifications table for the maximum permissible load.
3. Choose a position in the combustion air control to produce a gentle, long-lasting burn, avoid uncontrolled burning with the air control left open.
4. Keep the ash bed away from the primary air slots at the front of the fire.

Notes:

Only reload with wood when the previous load has been fully consumed, do not overload the combustion chamber.

For well insulated houses or forced air ventilation in adjacent spaces, it is advisable to place a ventilation grid on an outside wall near the equipment of at least 100 cm² and always be unobstructed. In this way, you supply the surrounding space with a good source of oxygen so that it does not run out, and the air masses move in the right direction. As for the air inlet grills, it must be taken into account that they must be positioned in such a way that their obstruction is not easy. In the case of simultaneous operation with other heating appliances, sufficient oxygen must be ensured.



Warnings:

This appliance was not designed to work with the door open. Open the door for lighting and reloading only. Do not open the heater door suddenly or with the smoke control fully or partially closed, as the combustion chamber may overpressure, causing smoke or even flame out into the room.

Excessive combustion does not necessarily translate into more heating power nor into an increase of efficiency. Furnacing may also cause irreparable damage to the appliance if carried out for long periods of time.

In the event of malfunction, immediately extinguish combustion by closing the fuel inlet control and the smoke control, causing the fire to extinguish by itself due to lack of oxygen. Expose the problem to our services and / or agents to be resolved.

7-Cleaning and Maintenance

To get the best out of your appliance, it should be regularly maintained and the flue regularly swept.



Cleaning and maintenance should always be carried out when the appliance is cold.

Cleaning

- The glass should be kept reasonably clean by the airwash.
In cases where a log has been left too close to or touching the glass, or green wood/kindling has been used then use a glass cleaner available from your retailer.
Ensure the glass cleaner does not come into contact with the metal parts or the rope seal.
- When removing excess ash when/as required when fire is cool, place ash in a non-combustible container with a tightly fitting lid and move outdoors immediately to a location clear of combustible materials.

Maintenance

- At the end of the winter season, at which point the appliance will be out of use for some time, thoroughly clean out the ash and residues inside it without using any abrasive products.
- With the aid of a vacuum cleaner, vacuum the secondary air heating chamber above the lower baffle bricks.
- Over time, you may feel that the appliance needs to be repainted, if that is the case, paint the equipment using high temperature spray paint. Paint the equipment only when it is completely cold. Before painting, carefully cover any areas you do not want to soil (glass and fireplace) and follow the instructions on the paint can. Note the paint will produce a small odour in the first few firings, it is recommended to have a small fire initially and keep windows open for ventilation.
- Clean the chimney and the flame baffle at least once a year using a qualified technician if necessary.
- Periodically check and replace the door seal.
- Use only ADF recommended replacement parts.

Fire Hazard

Your ADF equipment has been designed in accordance with existing legislation and in order to minimize any risk of fire in the chimney, however in such cases:



	AS	NZS
	000	111

1. Keep calm and make sure the area is safe.
2. Close the stove door completely.
3. Completely close the combustion air inlet and, if possible to do safely, cover the flue/chimney outlet.
4. The fire should be extinguished by itself due to lack of oxygen.
5. In the absence of safety conditions, move away from danger and request immediate rescue to Firefighters through the emergency number: 000 for Australia.
6. Before using the appliance again, have the chimney inspected and cleaned by a qualified technician.

8-Troubleshooting

If you comply with the instructions given in this manual, you should not have any major problem in enjoying your appliance. However, before requesting service, please check the following:



1. All the instructions given in this manual are complied with.
2. If there has been any recent change in the periphery that may have given rise to the problem.
3. If the problem falls into the following points.

Problem (s)	Possible Cause	Correction
The appliance is smoking	<ul style="list-style-type: none"> → Closed smoke damper regulation (when door open) → Wet or green firewood. → Dirty or clogged chimney. 	<ul style="list-style-type: none"> → Check the baffle is moving freely when opening door. → Use drier wood. → Clean the chimney.
Weak or inefficient burn	<ul style="list-style-type: none"> → Wet or green firewood. → Dirty or clogged chimney. → Insufficient firewood. 	<ul style="list-style-type: none"> → Use dry wood. → Clean the chimney.
Very fast burning	<ul style="list-style-type: none"> → Low density firewood. → Poorly adjusted door → Filling cord consumed 	<ul style="list-style-type: none"> → Load the stove with more dense firewood. → Door readjustment → Replacement of the cord
The fire extinguishes	<ul style="list-style-type: none"> → Wet or green firewood. → The appliance is not heated enough. 	<ul style="list-style-type: none"> → Use drier wood. → Leave the air lever open for longer to get a bed of coals before turning to low.
Blower not working	<ul style="list-style-type: none"> → The thermostat's operating temperature has not been reached → Power failure 	<ul style="list-style-type: none"> → Load more firewood → Check outlets and connections
Dirty glass	<ul style="list-style-type: none"> → Wet or green firewood. → Logs too close to or resting on the glass. 	<ul style="list-style-type: none"> → Slightly open the air inlet control → Use dry wood. → Keep logs parallel to and away from glass.

If the problem persists, please contact your retailer of the original purchase, to assist you to resolve the problem.

9-Warranty Conditions

Warranty:

ADF offers the purchaser of this appliance a limited 5-year warranty against manufacturing defects from the date of purchase:

Equipment structure	5-year Warranty
Electrical components	2-year Warranty
Glass, Refractory Firebricks, Door seal, Glass, Flame Grate, Paint	Not covered by warranty as their use is out of the manufacturers control and subject to quality of firewood, and user operation.

The warranty is voided by any evidence of tampering by unauthorised persons, misuse or abuse, or if the product has not be used as per the instructions.

Conditions to activate the warranty:

1. The appliance must be within the time limits described above (the date from which the product was purchased will be considered as the start of the warranty period).
2. The complaint must be presented and validated by one of our agents and endorsed by ADF.
3. The installation, use and maintenance conditions described in this manual have been strictly respected and no misuse has occurred or changes or modifications to the product.
4. The Warranty is limited to the replacement / repair by the ADF or its agent of the components known to be damaged and excludes any other type of cover or damages.

Our goods come with guarantees that cannot be excluded under the Australian Consumer Law. You are entitled to a replacement or refund for a major failure and for compensation for any other reasonably foreseeable loss or damage. You are also entitled to have the goods repaired or replaced if the goods fail to be of acceptable quality and the failure does not amount to a major failure.

The benefits given under this Limited Warranty are in addition to other rights and remedies you have under the Australian Consumer Law that cannot be excluded.



Warranty Certificate

Reseller's name: _____

Model: _____ Serial number: _____

Sold to: _____ in: ____/____/____

Address: _____

Postal Code: ____ - ____ Tel: _____ Email: _____

Reseller's stamp

Client Signature

Note: The Warranty is limited to the replacement / repair by ADF or its agent of the components known to be defective and excludes any other type of coverage or compensation such as the costs of transportation, removal or reinstallation of the equipment.

ATTENTION

When the equipment is delivered, please check it.

The warranty only covers damage caused during transportation if notice was given and marked on the document acknowledging receipt of the device within 24 hours.

Data Labels Found on Appliance:

820

TESTED BY: AUSTRALIAN SOLID FUEL TESTING 3 GARDEN ST, MORWELL, VIC 3840 AUSTRALIA	Unit	TEST REPORT NO: ASFT17109 DATED: 11/2017
WHEN TESTED IN ACCORDANCE WITH AS/NZS 4012:2014 & AS/NZS 4013:2014 Burning Hardwood		
Maximum Average Heat Output	kW	9.7
Overall Average Efficiency	%	63
Particulate Emission Factor	g/kg	0.8
Maximum firewood load	kg	9.7
Minimum clearance distances from combustible materials	mm	See Page 10/15.
Flue Diameter	mm	200
		Manufactured by: A.D.F. Lda. Z.I. Relvinha, Sarzedo A.P. 55 3304-909 Arganil-Portugal

1000

TESTED BY: AUSTRALIAN SOLID FUEL TESTING 3 GARDEN ST, MORWELL, VIC 3840 AUSTRALIA	Unit	TEST REPORT NO: ASFT17106 DATED: 11/2017
WHEN TESTED IN ACCORDANCE WITH AS/NZS 4012:2014 & AS/NZS 4013:2014 Burning Hardwood		
Maximum Average Heat Output	kW	12.5
Overall Average Efficiency	%	64
Particulate Emission Factor	g/kg	1.2
Maximum firewood load	kg	13.7
Minimum clearance distances from combustible materials	mm	See Page 10/15.
Flue Diameter	mm	200
		Manufactured by: A.D.F. Lda. Z.I. Relvinha, Sarzedo A.P. 55 3304-909 Arganil-Portugal

