

# LINEA 85

(Model ADH820I AU)

Heat Output	▪	13.1kW ave Peak
Efficiency	▪	72% peak [63% ave]
Coverage	▪	up to 200m <sup>2</sup>
Emissions	▪	0.8 grams/kg

Coupled with a sleek European design and manufacture, ADF brings the next level in quality and functionality with the launch of the Linea 85 wood-burning fire.

Externally the Linea 85 has a minimalist design, with clean lines, and crisp edges. The spectacular large soot-free glass door ensures a beautiful and uninterrupted view of the flames and is easily opened with its removable handle. The firebox is constructed using high-strength 5mm quality steel.

These fires aren't only eye-catching, they operate beautifully. Internally a unique automatic flue damper significantly reduces smoke ingress to the room on re-fuelling, and a high-density vermiculite lining system insulates the combustion chamber providing better heat reflection. In addition the simplicity in design of the air wash and primary air system belies how well these fires function.

Since the beginning of its operations in 1976, ADF has been at the forefront of stove design and technology. Focusing on quality and innovation, its R&D laboratory facilities were created in the 1980s and, in 2004, the ISO 9001 quality management system was adopted. Acquiring an ADF wood burning appliance, isn't simply insuring heating solution for your home: it is comfort, dependability, well-being and a work of art.



## Clearances

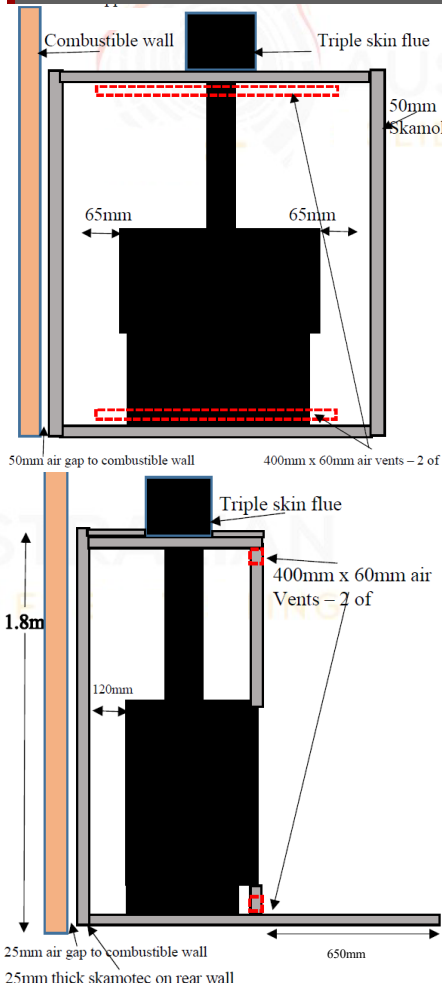

**CLEARANCES BASED ON INSTALLATION HAWKWIND 200MM TRIPLE SKIN FLUE KIT**

**HEARTH**  
950mm [w] x 565 [d] under the appliance, and 1070mm [w] x 650 [d] in front of the appliance. Thickness: equal to 18mm Bellis Board or equivalent

## Dimensions

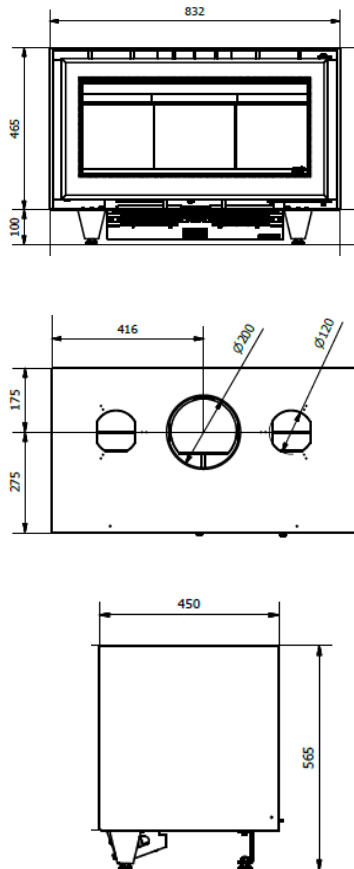

## Features

### STANDARD FEATURES

- Constructed using high-strength 5mm quality black steel
- Automatic flue damper system significantly reduces smoke ingress to the room on re-fuelling
- High density vermiculite lining system insulates the combustion chamber, providing better heat reflection
- Superior air wash system keeps the glass clean for unparalleled fire viewing
- Removable door handle, ensures a cool touch when stoking or refueling the fire
- Vertical smoke exit through the top
- Weight : 158kilos
- Maximum log width : 300mm
- Flue Spigot Size : 200mm
- Internal Firebox : 700[w] x 345[d] x 222-270[h]
- Viewing Area : 665[w] x 295[h]
- Warranty : Limited 5 years manufactures

### OPTIONAL ACCESSORIES

- Fan Assisted convection system [Quality German made Tangential Cross flow fan]
- Linea 85 Frames : [30mm Flat Edge or 30mm 4 sided Profil with a 20mm Return]

Information supplied is to assist you in your choice of a suitable fire. It is not intended to be all the information required to install the fire and does not replace the installation manual which provided more detailed information. In the interest of product development ADF reserves the right to change specifications without prior notice.

All measurements are in millimetres unless otherwise stated.