

ilekτρο Slimline

IS72

SPECIFICATION SHEET



Version 1 06/04/23

Contents of manual may be updated without notice.

For the latest version of this manual please refer to our website: www.paulagnewdesigns.com.au

PAUL AGNEW | **DESIGNS**

ilektro Slimline IS72

APPLIANCE DIMENSIONS

Product Code:

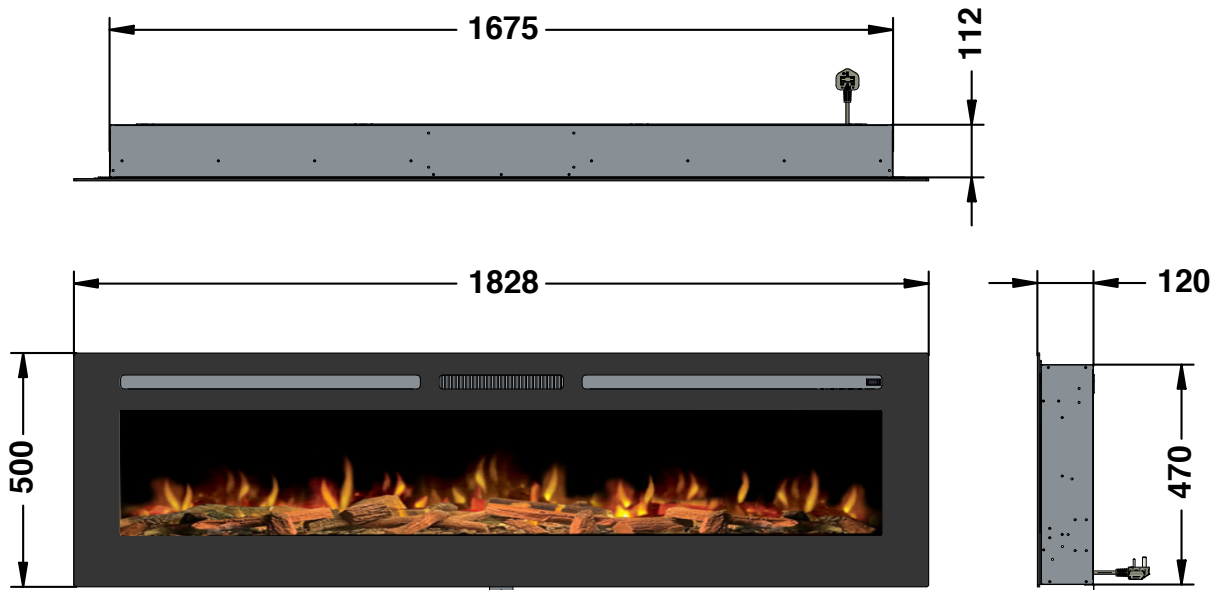

FRAME BUILD OUT DIMENSIONS (All dimensions are in millimetres)

H - MIN	W - MIN	C - CAVITY DEPTH
480	1684	120

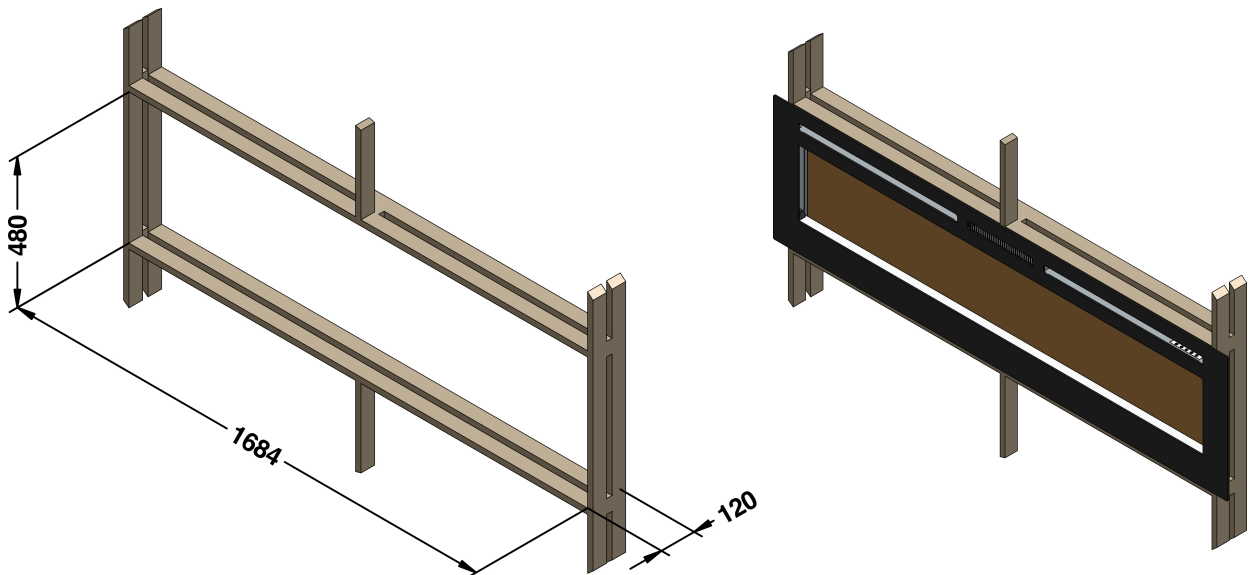

PLEASE NOTE: DIMENSIONS ARE FOR REFERENCE ONLY - CONSULT YOUR INSTALLER AND RETAILER FOR GUIDANCE

iléktró

148 Cochranes Road
Moorabbin, Victoria 3189

www.paulagnewdesigns.com.au

info@paulagnewdesigns.com.au